

MODEL CXCA048CRS4

SPECIFICATIONS:

- 48,000 BTU/HR at 95F degree ambient and 55F degree water out
- Electrical: 460V, 60hz three phase
- Minimum Circuit Ampacity: 11, Maximum Fuse Size 16 Amps
- (1) 50 gallon insulated stainless steel tank
- (1) 1 HP water pump: 47 GPM max, 49 PSI max
- (1) 4 Ton Copeland scroll compressor
- R410a Refrigerant
- Approximate shipping weight 800 LBS
- Dimensions: 48-1/4" wide, 74-1/4" long, 39-7/8" tall
- Decibels: 78

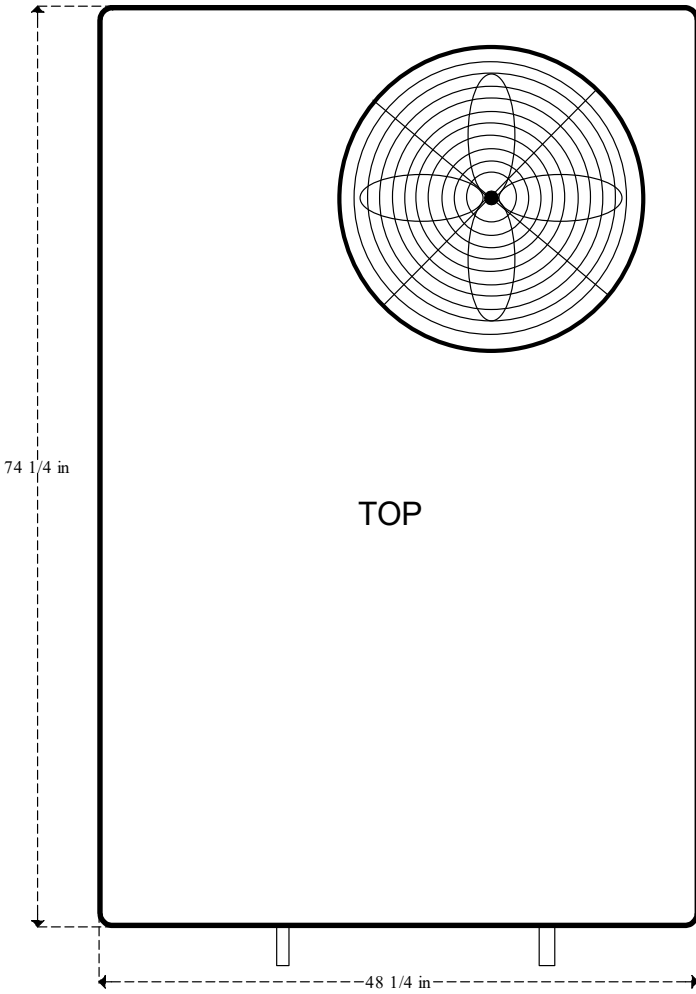

FRONT

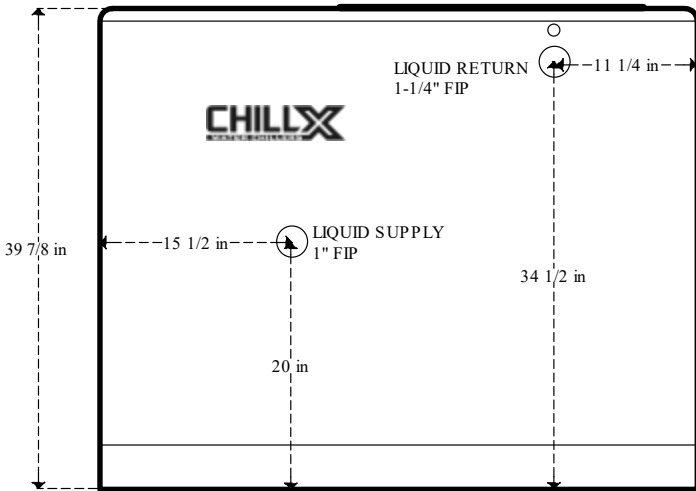

REAR

